

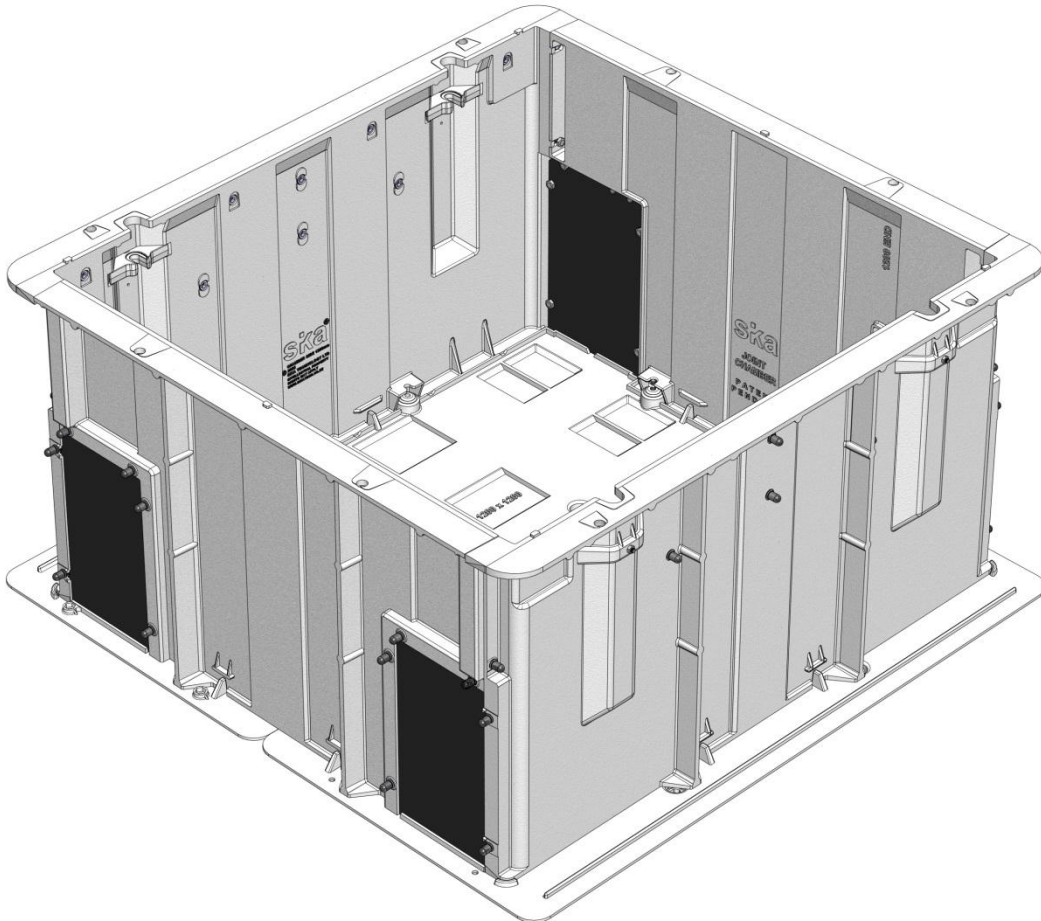

Modular Aluminium Jointing Chamber 1200 x 1200 x 700 / 900H

ASSEMBLY INSTRUCTIONS

Chamber Rating: CLASS D - 210kN - AS3996:2006
Sika 'Chambers' are used for both Pathway & Roadway Installations



Chamber 1200 x 1200 x 700H



1. Place the two 1200mm **chamber bases** side to side on a flat area adjoining the pit or on a prepared bed of imported material in the excavated pit. Note that the “1200 x 1200” scripts will be face up.
- Join the two **chamber bases** with the four **base joiner tabs** and apply 8 – M10 bolts and washers, and tighten.

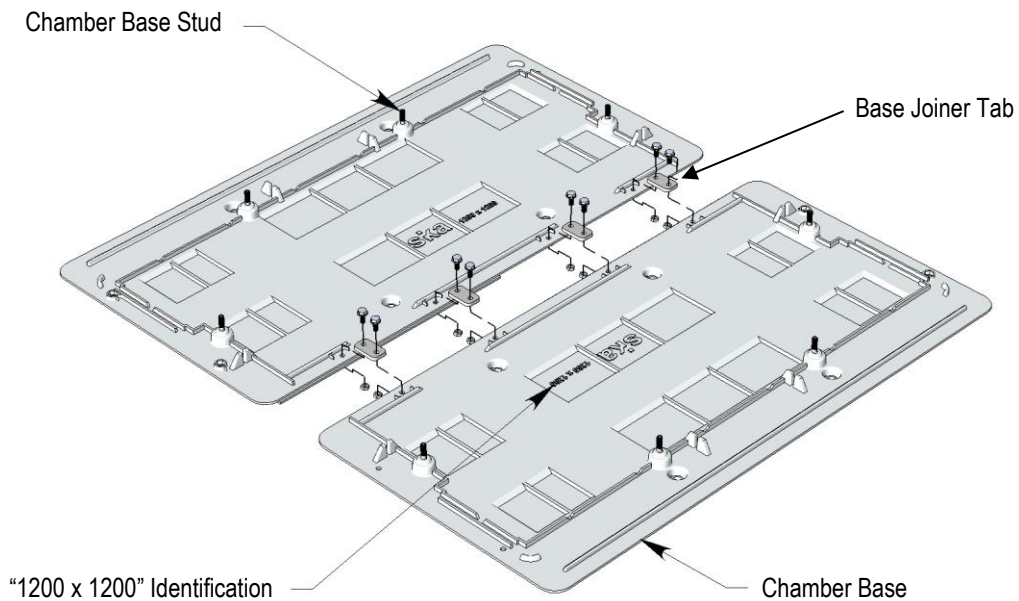

Fig 1

2. The **chamber base** may be assembled around existing duct work. Ref Fig 2

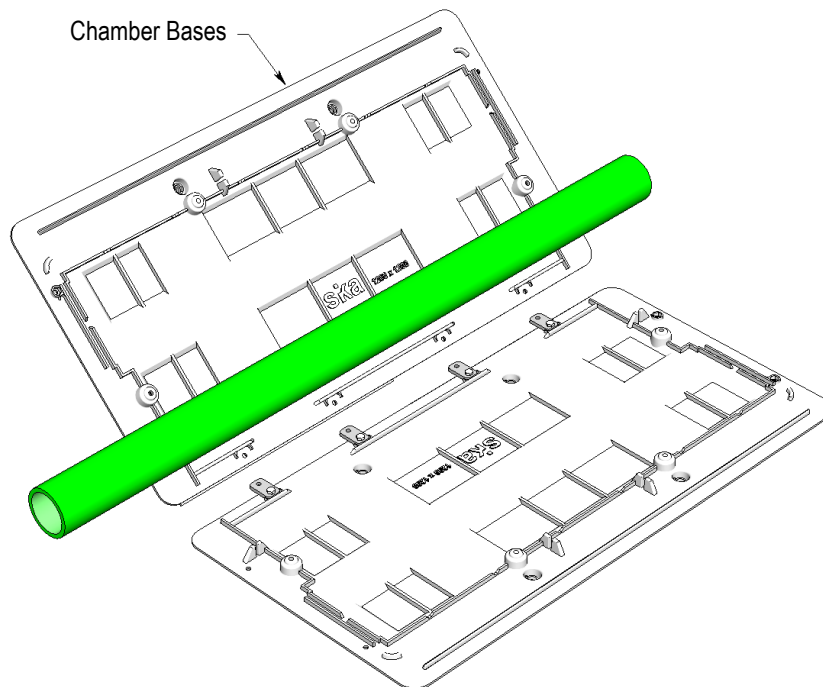

Fig 2

3. Remove the plastic tubes protecting the 4 – M10 studs protruding from the **chamber base** and place the two **chamber sides** into place.

Insert the two **chamber sides** into the appropriately marked positions on the **chamber base**. **Chamber side supports** cast into the **chamber base** will hold the **chamber sides** vertical until the 4 – M10 nuts and washers are applied to hold them down. *(Do not tighten these yet.)*

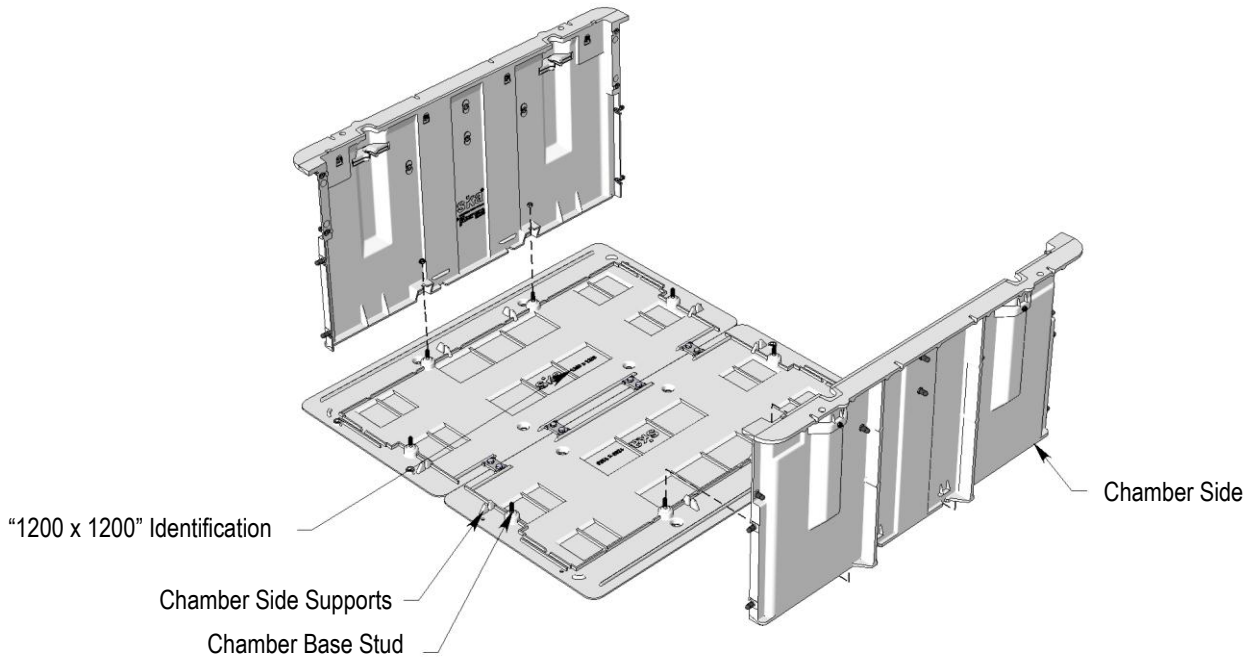

Fig 3

4. Remove the plastic tubes protecting the 4 – M10 studs protruding from the **chamber base** and place the two **chamber ends 1200** into place.

Insert the two **chamber ends** into the appropriately marked positions on the **chamber base** and secure them to the **chamber base** and **chamber sides** with the 12 – M10 x 30 bolts and washers. *(Now tighten all the aforementioned fixings.)*

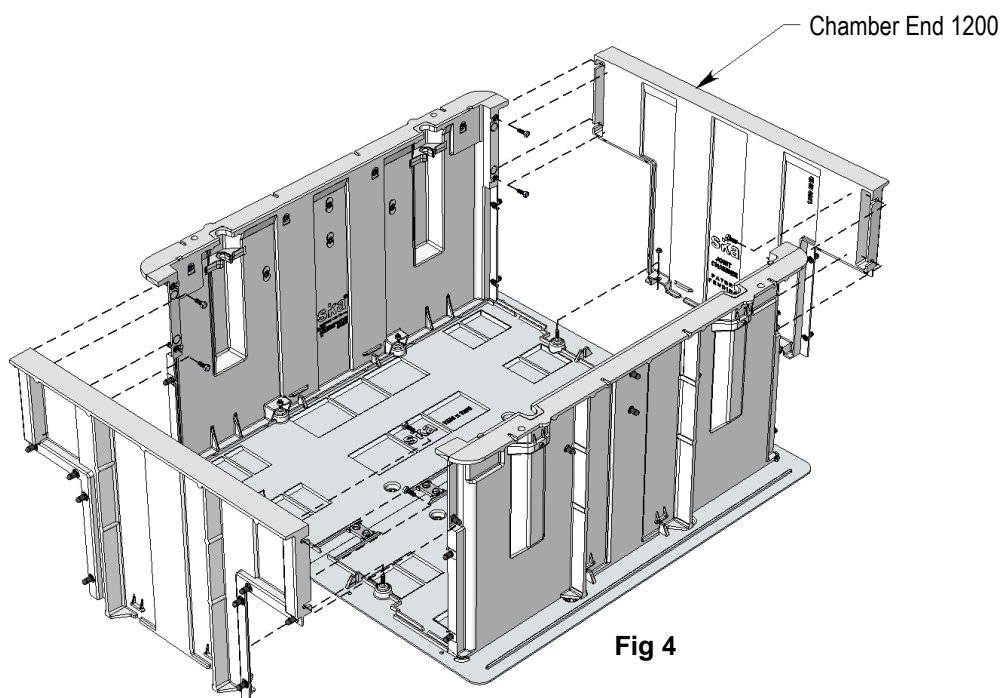

Fig 4

5. Apply the four polypropylene **duct entry panels** to each end recess and secure each one with 6 - M10 x 30 bolts and washers supplied.

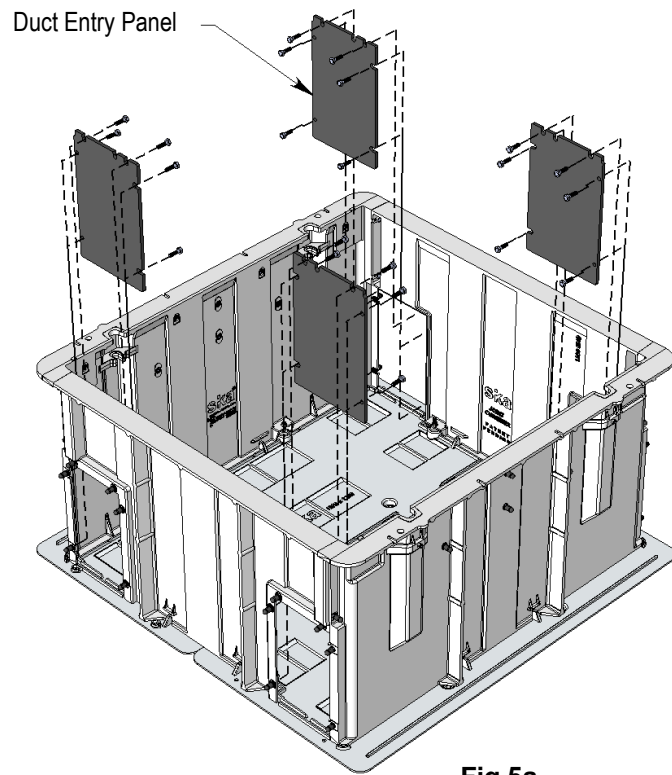

Fig 5a

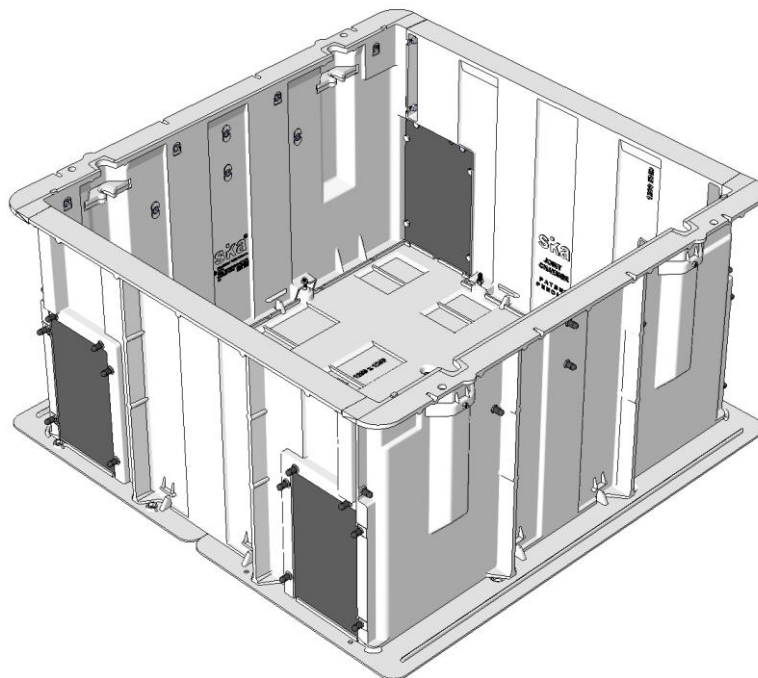
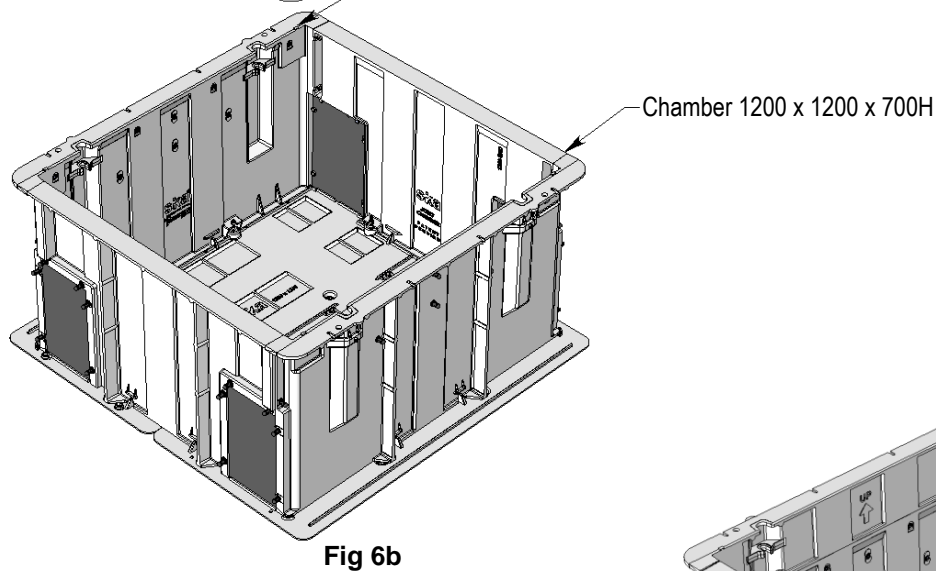
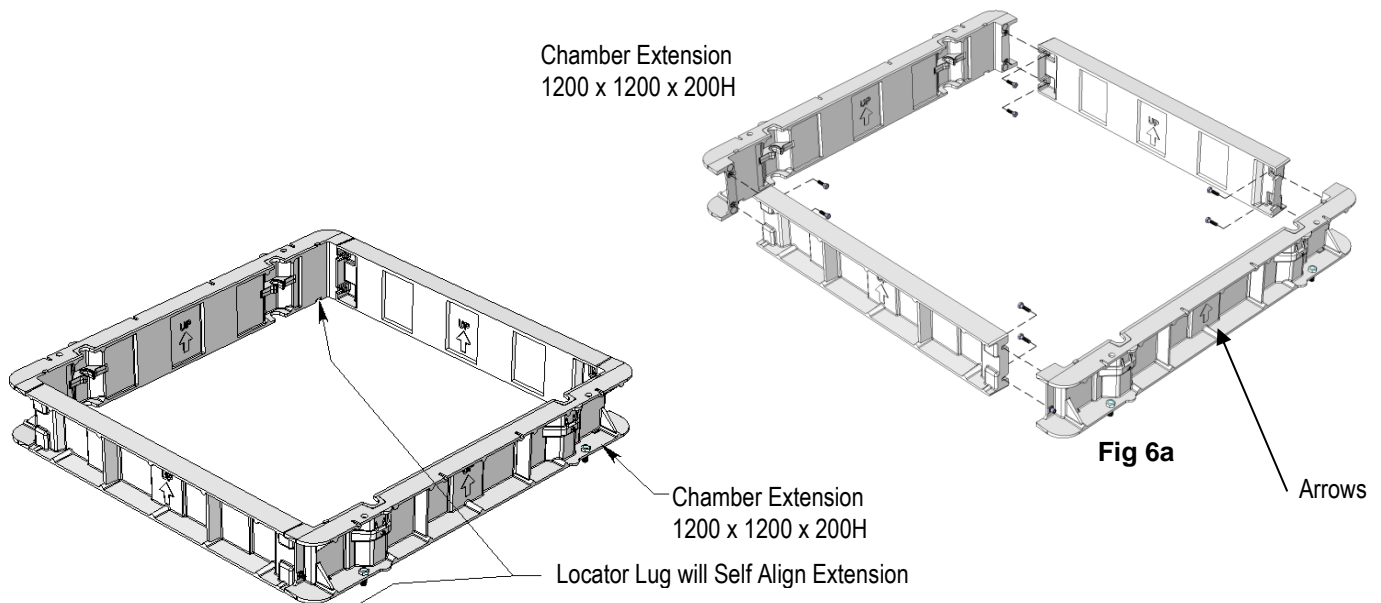

Fig 5b

Chamber 1200 x 1200 x 700H

Chamber Extension 200mm

6. Assemble **chamber extension** as per Fig 6a using 8 – M10 x 30 bolts and washers supplied. Place on top of chamber flange. See arrows for right way up.



Bolt assembled **chamber extension** to the chamber with the 8 – M16x40 bolts, nuts and spring washers supplied.

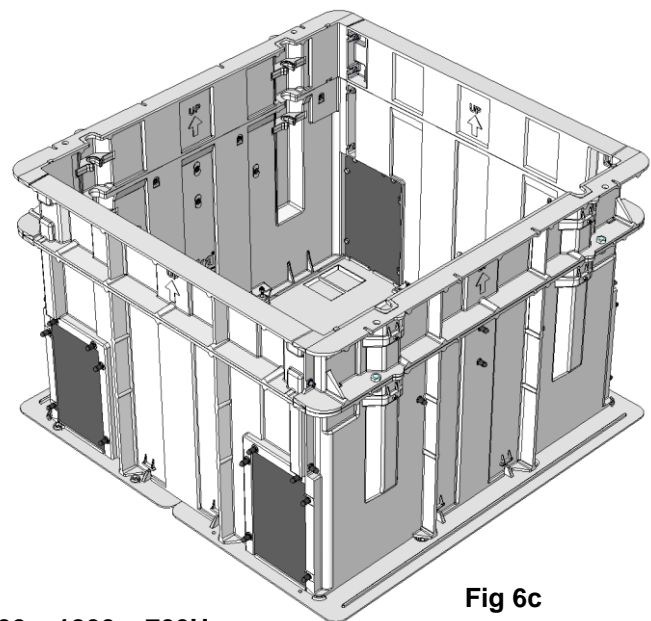

**Chamber 1200 x 1200 x 700H
& Extension 1200 x 1200 x 200H**

Chamber Accessories

Cable Support & Protection Options

