

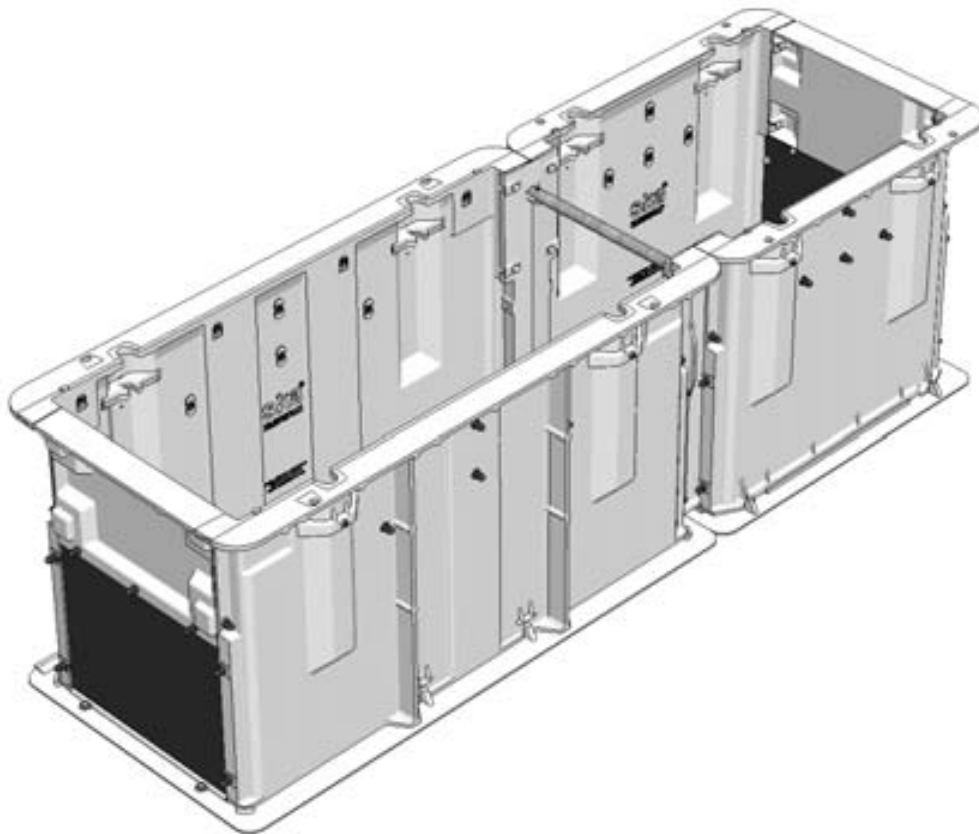

Modular Aluminium Jointing Chamber 2100 x 600 x 700 / 900H

ASSEMBLY INSTRUCTIONS

Chamber Rating: CLASS D - 210kN - AS3996:2006
Sika 'Chambers' are used for both Pathway & Roadway Installations



Chamber 2100 x 600 x 700H



1. Place the 1200mm and 700mm **chamber bases** end to end on a flat area adjoining the pit or on a prepared bed of imported material in the excavated pit. Note the “1200 x 600” script and Sika logos will be face up.

Place the **base joiner 600** where both **chamber bases** join and apply the 4 – M10 x 40 bolts and washers, and tighten.

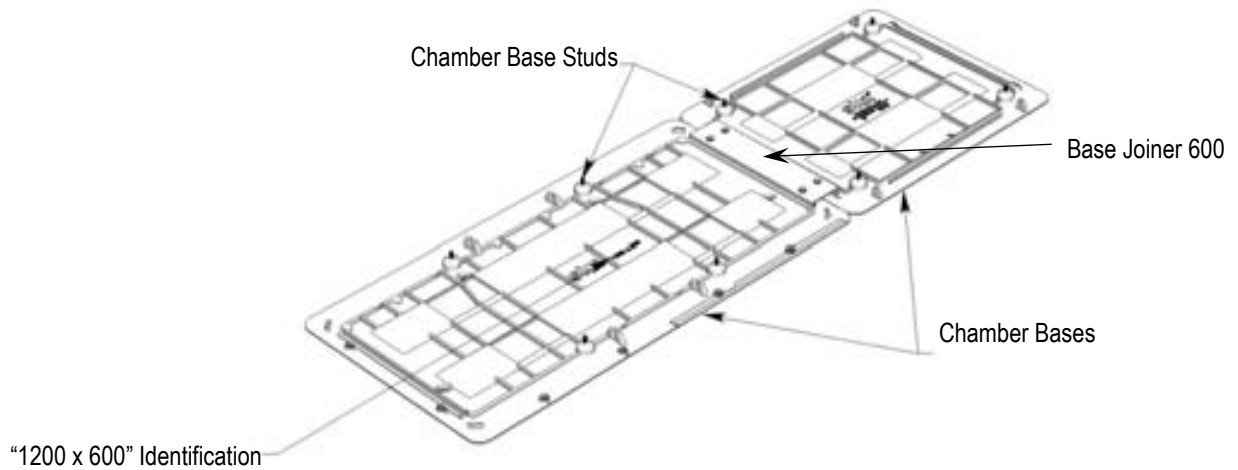

Fig 1

2. Where there is existing ducting and minimal side excavation is required use a **split base**. Ref Fig 2

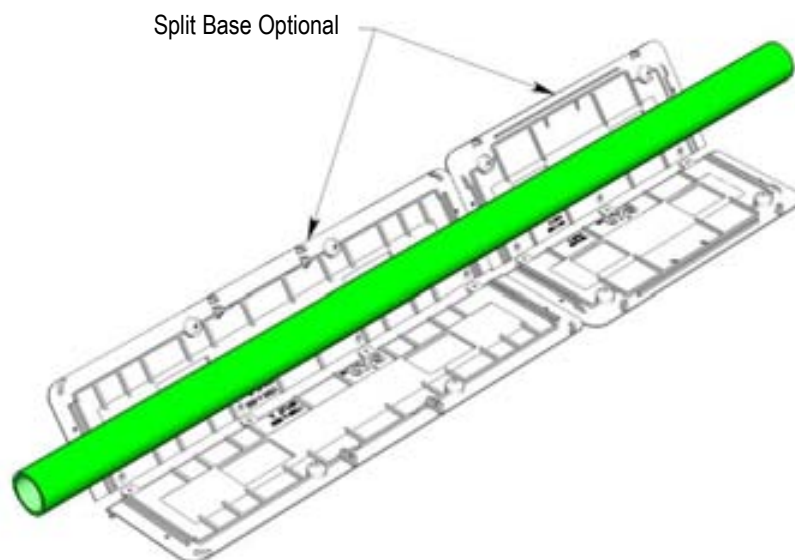
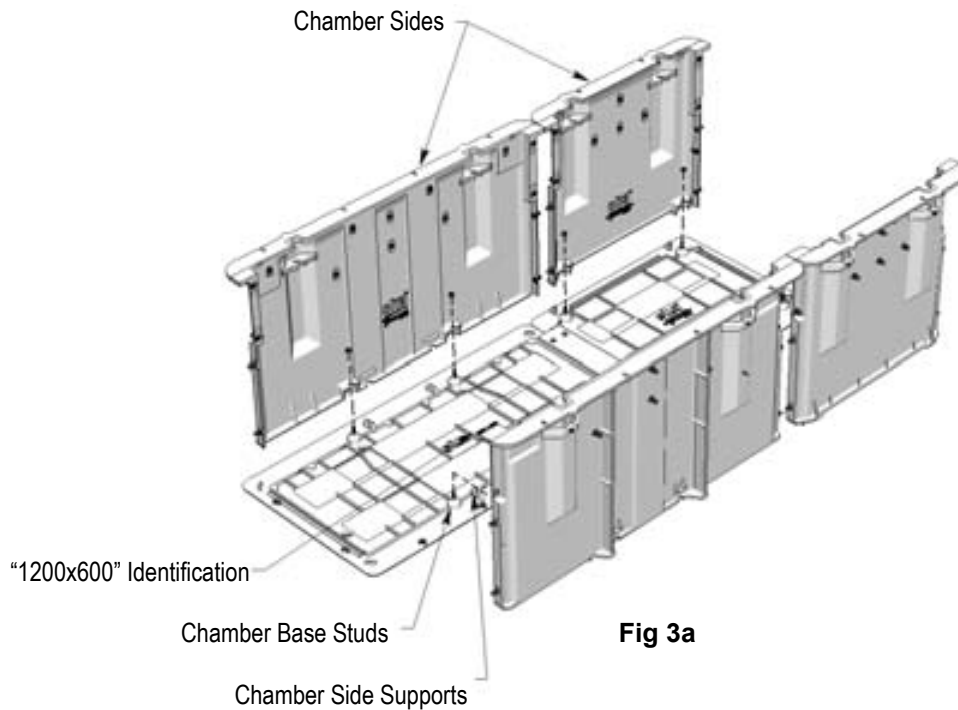

Fig 2

3. Remove the plastic tubes protecting the 8 – M10 studs protruding from the **chamber base** and place the 2 – 1200 and 2 – 700 **chamber sides** into place.

Insert the four **chamber sides** into the appropriately marked positions on the **chamber base**. **Chamber side supports** cast into the **chamber base** will hold the **chamber sides** vertical until the 8 – M10 nuts and washers are applied to hold them down. *(Do not tighten these yet.)*



Add the two **side joiners 700** adjacent to the **base joiner 600** using 16 – M10 x 30 bolts and washers.

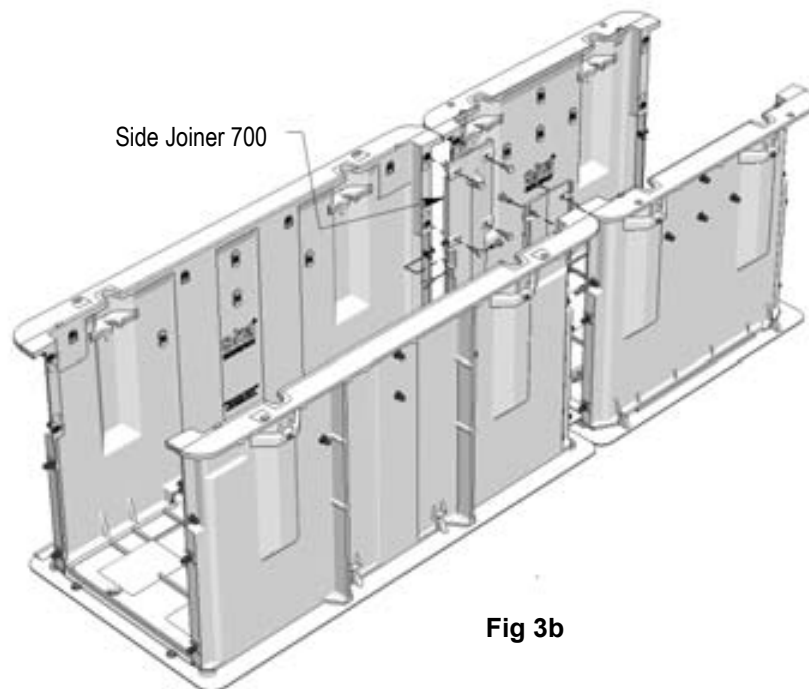

4. Add the two **chamber ends 600** and secure them with the 8 – M10 x 30 bolts and washers.
(Now tighten all the aforementioned fixings)

Chamber End 600

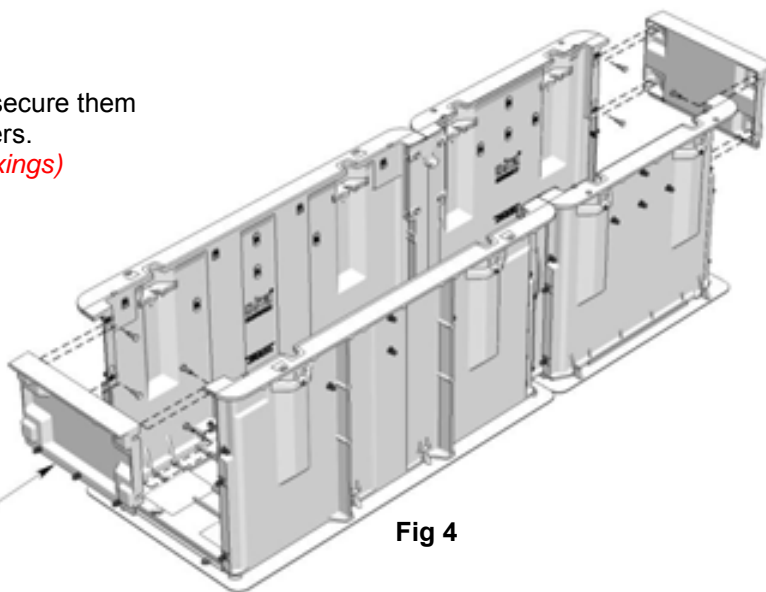

Fig 4

Duct Entry Panel

5. Apply the two polypropylene **duct entry panels** to each end recess and secure each one with 7 – M10 x 30 bolts and washers supplied.

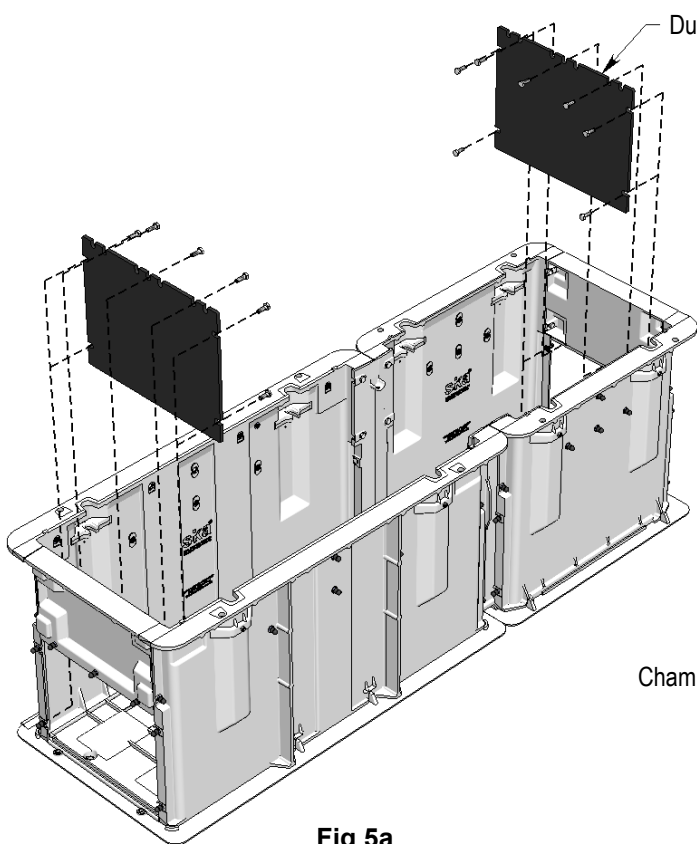

Fig 5a

Align and fit the **chamber spreader 600** in place between the two **side joiners 700**.
Ref Fig 5b

Chamber Spreader 600

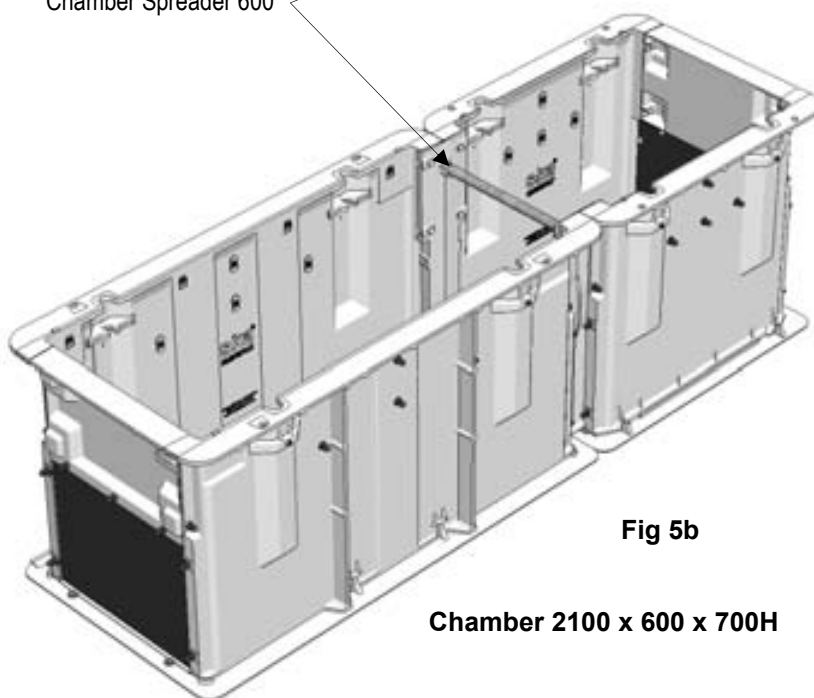
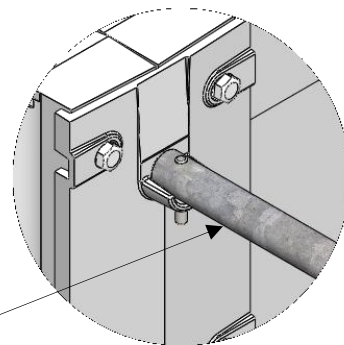
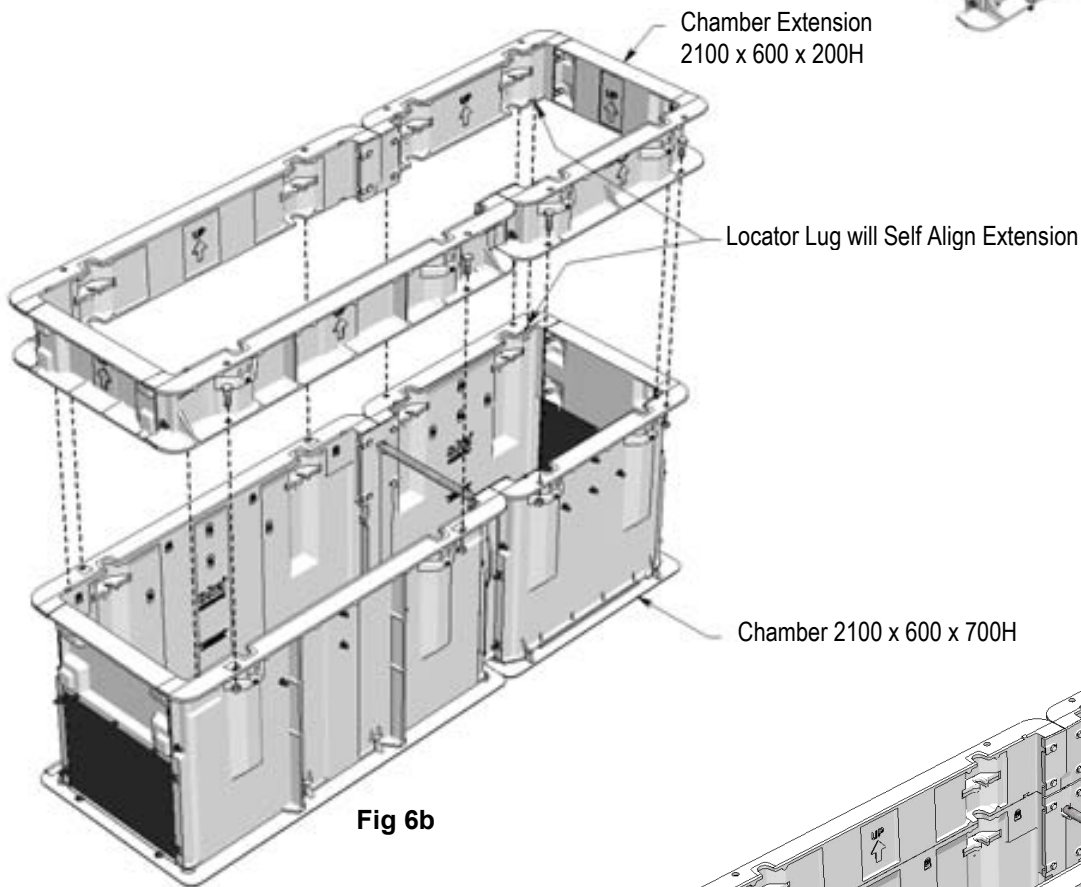
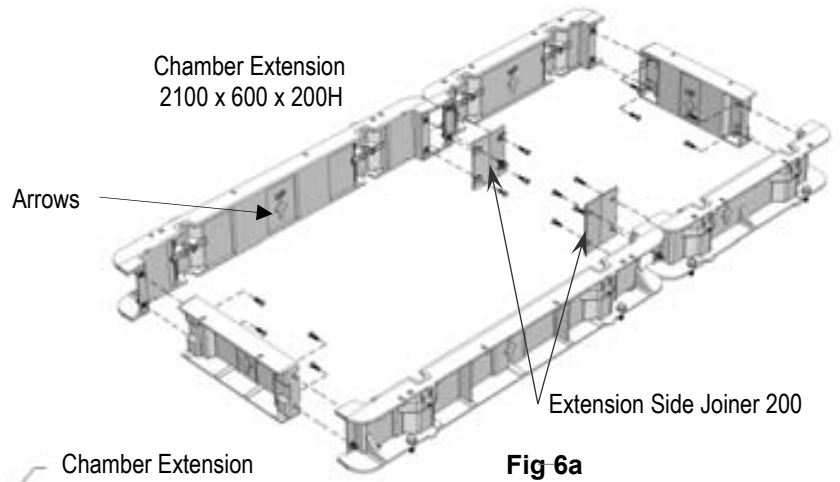

Fig 5b

Chamber 2100 x 600 x 700H

Chamber Extension 200mm

6. Assemble **chamber extension** as per Fig 6a using the **extension side joiners 200** and 16 – M10 x 30 bolts and washers supplied. Place on top of chamber flange. See arrows for right way up.



Bolt assembled **chamber extension** to the chamber with the 8 – M16x40 bolts, nuts and spring washers supplied.

**Chamber 2100 x 600 x 700H
& Extension 2100 x 600 x 200H**

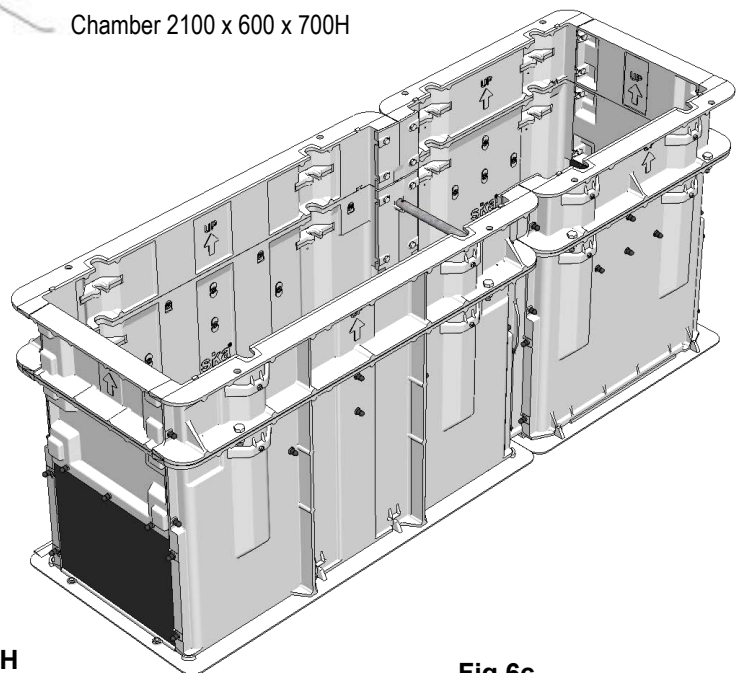

Chamber Accessories

Cable Support & Protection Options

Cable Protection Plate

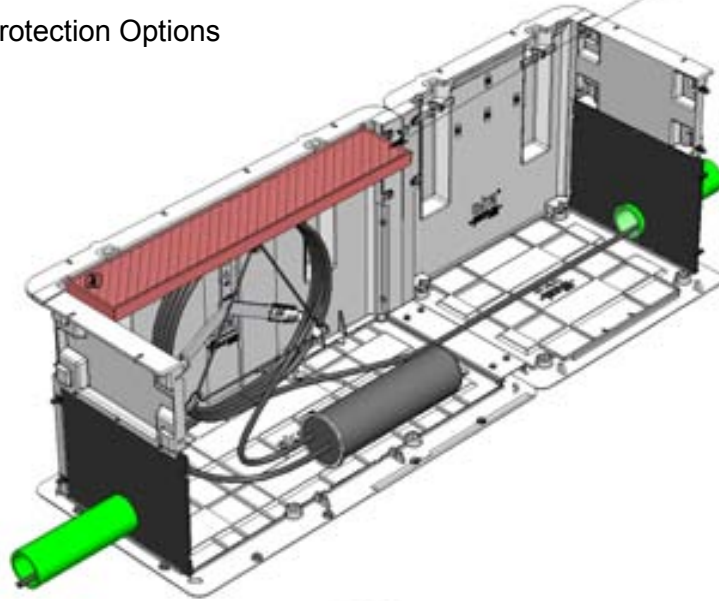

Cable Management Bracket

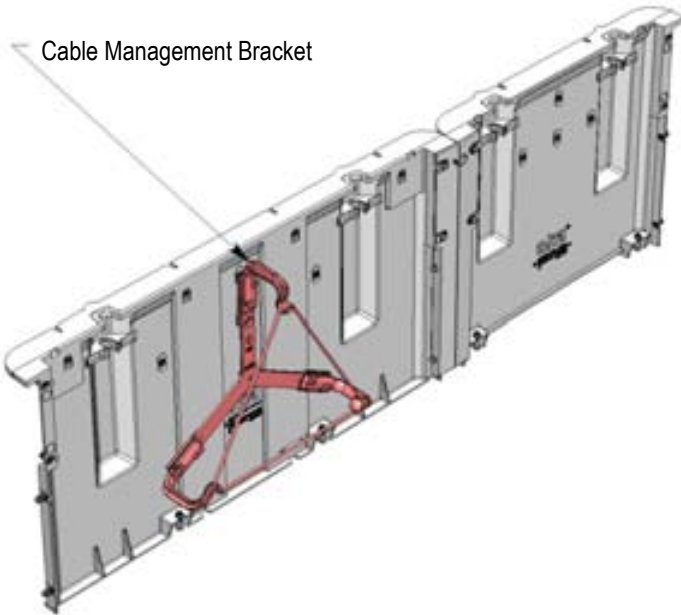

Cable Stirrup Bracket
Option 145 mm Long
Option 250 mm Long

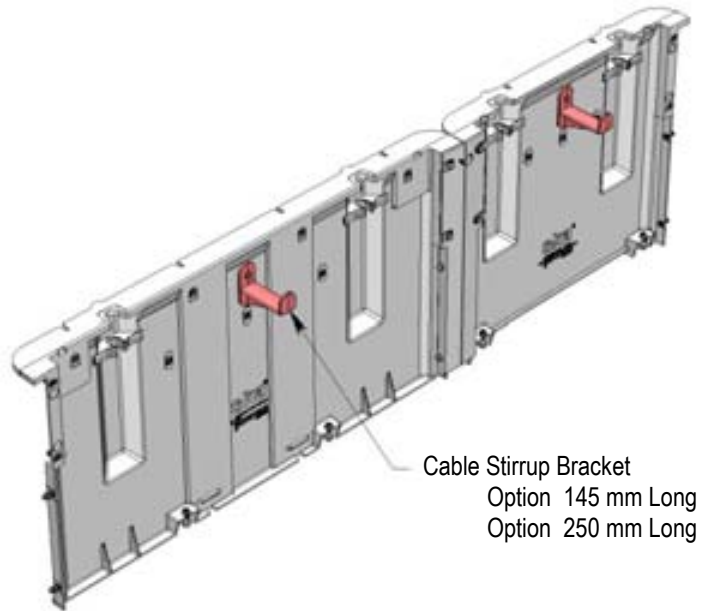

'J' Brackets

